

CLARKE[®]

METALWORKER



425W RADIAL ARM DRILL PRESS

MODEL NO: CDP425RA

PART NO: 6550036

OPERATION & MAINTENANCE INSTRUCTIONS

UK
CA | CE



ORIGINAL INSTRUCTIONS

DL0126 Rev 2

INTRODUCTION

Thank you for purchasing this CLARKE Drill Press.

Before attempting to use this Drill Press please read this manual thoroughly and follow the instructions carefully. In doing so you will ensure the safety of yourself and that of others around you, and you can look forward to your purchase giving you long and satisfactory service.

IMPORTANT

Please read all of the safety and operating instructions carefully before using this product. Please pay particular attention to all sections of these instructions that display warning symbols and notices.

GUARANTEE



This product is guaranteed against faulty manufacture for a period of 12 months from the date of purchase. Please keep your receipt which will be required as proof of purchase.

This guarantee is invalid if the product is found to have been abused or tampered with in any way, or not used for the purpose for which it was intended.

Faulty goods should be returned to their place of purchase, no product can be returned to us without prior permission.

This guarantee does not effect your statutory rights.

SAFETY SYMBOLS

	Fully read this manual and safety instructions before use		Eye protection should be worn
	Dust mask should be worn		

GENERAL SAFETY RULES



WARNING: WHEN USING ELECTRIC TOOLS, BASIC SAFETY PRECAUTIONS SHOULD ALWAYS BE FOLLOWED TO REDUCE THE RISK OF FIRE, ELECTRIC SHOCK AND PERSONAL INJURY INCLUDING THE FOLLOWING. READ ALL THESE INSTRUCTIONS BEFORE ATTEMPTING TO OPERATE THIS PRODUCT AND SAVE THESE INSTRUCTIONS FOR FUTURE REFERENCE.

GENERAL SAFETY IN THE WORKPLACE

1. **ALWAYS** ensure that air can circulate around the machine and that the air vents are unobstructed.
2. **ALWAYS** keep work area clean & tidy. Cluttered work areas and benches invite accidents.
3. **NEVER** over-reach. Keep proper footing and balance at all times.
4. **NEVER** store equipment in a wet/damp environment or expose to rain.
5. **KEEP** other persons away. Do not let persons, especially children, not involved in the work, touch the tool or extension cable and keep them away from the work area.
6. **NEVER** operate a machine when under the influence of alcohol, drugs or medication.
7. **ALWAYS** ensure the workplace is well lit. Ensure that lighting is placed so that you will not be working in your own shadow.
8. **DO NOT** use power tools in the presence of flammable liquids or gasses.
9. Stay alert, watch what you are doing, use common sense and **DO NOT** operate the power tool when you are tired.

CARE OF POWER TOOLS

1. Read this manual carefully. Learn the machines applications and limitations, as well as its specific potential hazards.
2. **ALWAYS** keep guards in place and in working order. A guard or other part that is damaged should be properly repaired or replaced by an authorised service centre, unless otherwise indicated in this instruction manual.
3. Remove any adjusting keys or wrenches before starting. Form the habit of checking to ensure that keys, wrenches and tools are removed from the machine.
4. **DO NOT** force the machine and use the correct tools/bits. It will do the job better and safer, at the rate for which it was intended.

5. **ALWAYS** disconnect the machine from the power supply before carrying out any servicing or changing of accessories.
6. Before further use of the tool, it should be carefully checked to determine that it will operate properly and perform its intended function. Check for alignment of moving parts, binding of moving parts, breakage of parts, mounting or other condition that may affect its operation.
7. Have defective switches repaired by your CLARKE Service Department. **DO NOT** use a tool if the switch does not turn it on and off.
8. **ALWAYS** check for any damage or any condition that could affect the operation of the machine. Damaged parts should be properly repaired.
9. **NEVER** remove the cover panel unless the machine is disconnected from the power supply, and never use the machine with cover panels removed.
10. Have your machine repaired by a qualified person. This machine complies with the relevant safety rules. Repairs should only be carried out by qualified persons using original spare parts, otherwise this may result in considerable danger to the user.
11. **NEVER** use this product for any other purpose than that described in this booklet.
12. **NEVER** abuse the power cable by yanking the cable to disconnect it from the socket. Keep the cable away from heat, oil or sharp edges.
13. Guard against electric shock. Avoid body contact with earthed surfaces.
14. If the machine should be used outdoors, use only extension cables intended for outdoor use and marked accordingly.
15. **AVOID** accidental starting by making sure the power switch is off before plugging in the power cable.

ADDITIONAL SAFETY RULES FOR DRILL PRESSES



CAUTION: AS WITH ALL MACHINERY, THERE ARE CERTAIN HAZARDS INVOLVED WITH THEIR OPERATION AND USE. EXERCISING RESPECT AND CAUTION WILL CONSIDERABLY LESSEN THE RISK OF PERSONAL INJURY. HOWEVER, IF NORMAL SAFETY PRECAUTIONS ARE OVERLOOKED, OR IGNORED, PERSONAL INJURY TO THE OPERATOR, OR DAMAGE TO PROPERTY MAY RESULT.

1. **IMPORTANT:** You should not operate this machine unless you are thoroughly familiar with drilling machines and drilling techniques. If there is any doubt whatsoever you should consult a qualified person.
2. **NEVER** operate the machine until it is completely assembled and you have read and understood this entire manual.
3. **ALWAYS** use clamps or a drill vice bolted to the table, to hold the work. It should never be held with bare hands.
4. **ALWAYS** shut off the power & remove drill bit before leaving the machine.

5. **ALWAYS** make all adjustments with the power off.
6. **ALWAYS** use the correct drilling speeds for the drill size and the type of material being drilled.
7. **NEVER** leave the drill unattended whilst it is running. Turn the machine OFF and do not leave until it has come to a complete stop.
8. **ALWAYS** remove and store the drill bits when you have finished work.
9. **NEVER** attempt to drill into a workpiece that does not have a flat surface unless a suitable support is used.
10. **ALWAYS** stop the drill before removing workpieces, work supports or swarf from the table.
11. Keep drills sharp and clean for best and safest performance. Follow instructions for changing accessories.
12. Adjust the table or depth stop to avoid drilling into the table surface.
13. **ALWAYS** be sure that the drill bit is securely locked in the chuck.
14. **NEVER** assemble or set up any work on the table while the drill is running.
15. **ALWAYS** ensure the table lock is tight before starting the drill.
16. Keep handles dry, clean and free from oil and grease.
17. **ALWAYS** keep hands and fingers away from the drill bit.



WARNING: DUST GENERATED FROM CERTAIN MATERIALS CAN BE HAZARDOUS TO YOUR HEALTH. ALWAYS OPERATE THE DRILL IN A WELL VENTILATED AREA. USE A DUST COLLECTION SYSTEM IF POSSIBLE.

WARNING: THE USE OF ANY ACCESSORY OR ATTACHMENT OTHER THAN ONE RECOMMENDED IN THIS INSTRUCTION MANUAL MAY PRESENT A RISK OF PERSONAL INJURY.

PROTECTIVE CLOTHING

1. Dress properly. Loose clothing or other jewellery may get caught in moving parts. Non-slip footwear is recommended. Wear protective hair covering to contain long hair.
2. **ALWAYS** wear safety glasses. (Everyday glasses are not safety glasses.)
3. Wear a face mask if drilling into any material which produces dust.

ELECTRICAL CONNECTIONS



WARNING! READ THESE ELECTRICAL SAFETY INSTRUCTIONS THOROUGHLY BEFORE CONNECTING THE PRODUCT TO THE MAINS SUPPLY.

Before switching the product on, make sure that the voltage of your electricity supply is the same as that indicated on the rating plate. This product is designed to operate on 230VAC 50Hz. Connecting it to any other power source may cause damage.

This product may be fitted with a non-rewireable plug. If it is necessary to change the fuse in the plug, the fuse cover must be refitted. If the fuse cover becomes lost or damaged, the plug must not be used until a suitable replacement is obtained.

If the plug has to be changed because it is not suitable for your socket, or due to damage, it should be cut off and a replacement fitted, following the wiring instructions shown below. The old plug must be disposed of safely, as insertion into a mains socket could cause an electrical hazard.

If the colours of the wires in the power cable of this product do not correspond with the markings on the terminals of your plug, proceed as follows.

- The **Blue** wire must be connected to the terminal marked **N** or coloured **Black**.
- The **Brown** wire must be connected to the terminal marked **L** or coloured **Red**.
- The **Yellow and Green** wire must be connected to the terminal marked **E** or  or coloured **Green**.

Plug must be BS1363/A approved.

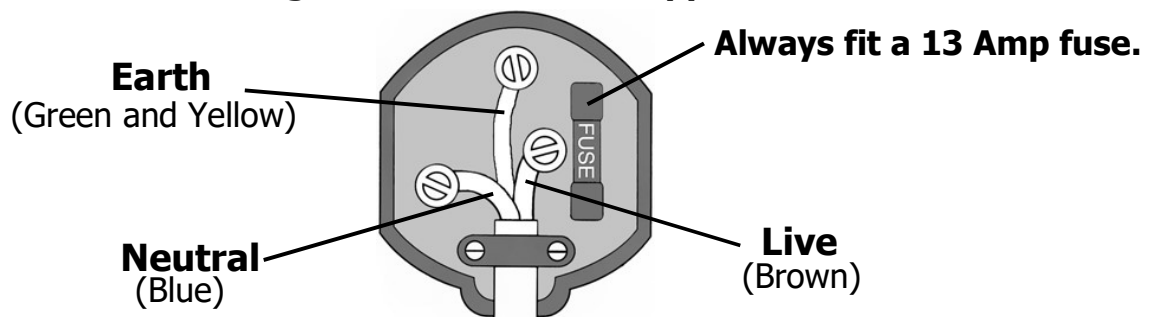

Ensure that the outer sheath of the cable is firmly held by the clamp

We strongly recommend that this machine is connected to the mains supply via a Residual Current Device (RCD). If in any doubt, consult a qualified electrician. **DO NOT** attempt any repairs yourself.

GET TO KNOW YOUR DRILL PRESS

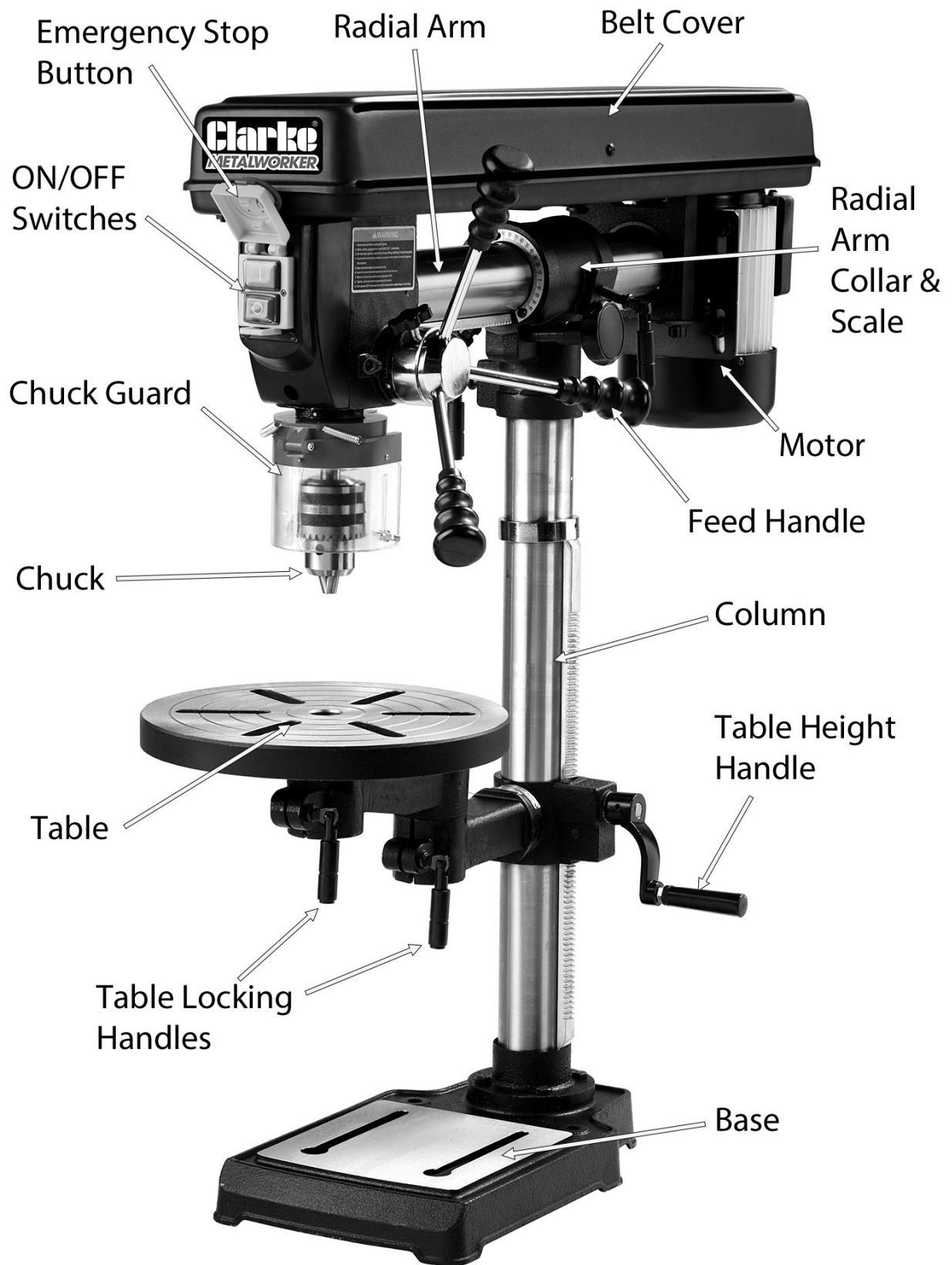

UNPACKING

The drill press is delivered with the components shown below.

Check the parts against the list. Should there be any deficiencies or damage, you should contact your CLARKE dealer immediately where the product was originally purchased. **DO NOT** discard the packaging until the drill press is assembled. The packaging consists of cardboard and appropriately marked materials which can be sent to a re-cycling facility.

To protect the machine parts from moisture, a protective coating of light machine oil will have been applied to the outside surfaces. Remove any excess with a paper towel.

Take care when lifting the head assembly, considering its weight.

NO	DESCRIPTION	NO	DESCRIPTION
1	Head, Motor & Radial Arm Assembly	9	Column
2	Table	10	Table Height Handle
3	Table Support Arm (x2)	11	Feed Handles (x3)
4	Base	12	Hex Keys (S3, S4)
5	Chuck	13	Hex Bolts M8 x 20 (x4)
6	Chuck Key	14	Locking Handles (x5)
7	Chuck Guard	15	Key Drift
8	Locking Shoe		

ASSEMBLY

This machine is designed for bench mounting and before use, it should be mounted and securely bolted to a strong, heavy workbench, of sufficient height that you will be standing upright when working.

Ensure the work place is adequately lit, and that you will not be working in your own shadow.

COLUMN TO BASE

Bolt the column to the base with the bolts and washers provided.

NOTE: Ideally, the base with column attached, should be firmly bolted (bolts not supplied) to the workbench prior to the assembly of other components.

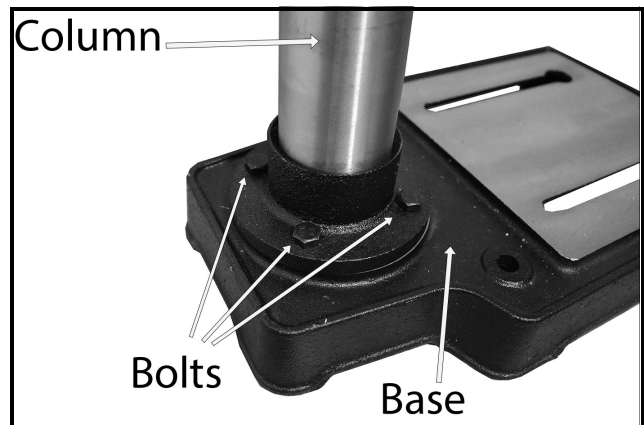
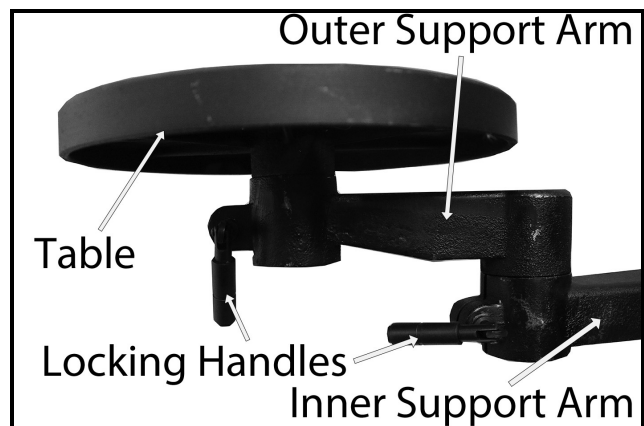
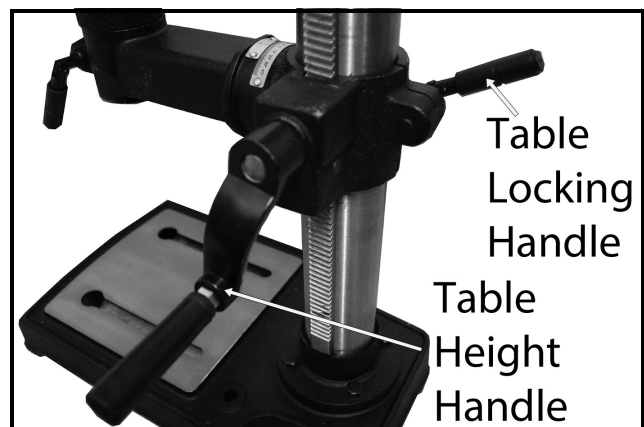

TABLE TO COLUMN

1. Thread a table locking handle into the table support collar and leave it loose at this stage.
2. Slide the table support down the column until it sits on the ratchet teeth.
3. Place the table height handle on the side of the table support and tighten using a hex key.
4. To move the table up or down, loosen the locking handle and turn the height handle to set the table at the require position. Then re-tighten the locking handle.
5. Place the table on to the table outer support arm and place the outer support arm on to the inner support arm, thread a table locking handle into the table support arms and tighten.



HEAD TO COLUMN

1. Place the locking shoe inside the collar on the radial arm and screw in the locking handle to meet it.
2. Lift the head and motor assembly and locate it on top of the column, ensuring it slides home fully.

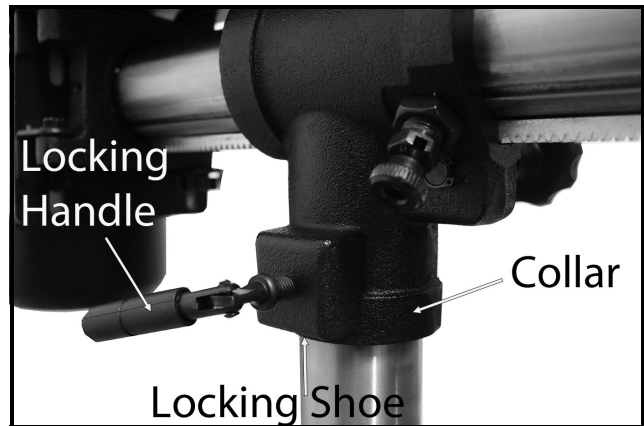

3. Align the head with the base and firmly secure it to the column with the locking handle.
4. Screw the three feed handles firmly into the hub as shown.

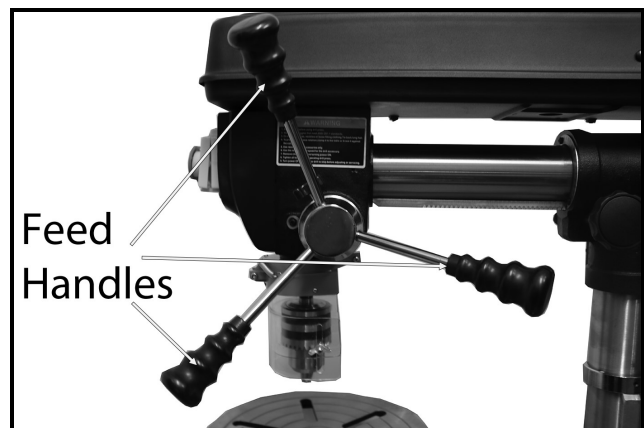

INSTALLING THE CHUCK

1. With the chuck guard lifted clear of the spindle, slide the work table up the column to within 6" of the spindle.
2. Fully open the jaws of the chuck using the chuck key supplied.
3. Put a piece of scrap wood on the table to protect the chuck nose as shown.
4. Ensuring all parts are thoroughly clean, dry, and burr free, place the chuck into the end of the open spindle and pull the spindle down using the feed handles. Press the chuck jaws hard against the piece of scrap wood until the chuck is forced home. Discard the scrap wood.
5. When the chuck is installed, turn the chuck guard around so that the shield is facing the front and tighten the pinch bolt to align the guard.

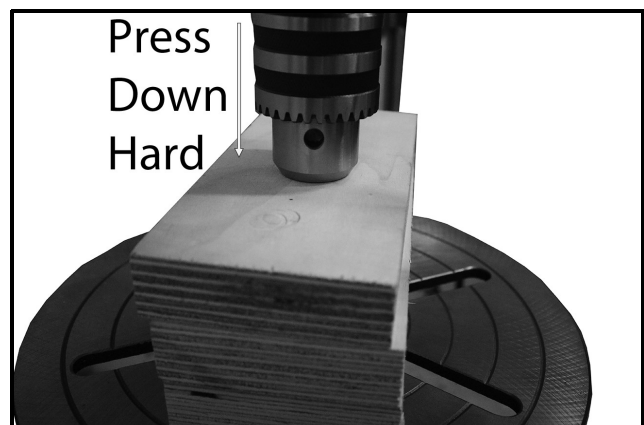

CHUCK GUARD ASSEMBLY

1. Unscrew the collar of the chuck guard and slide the collar over the chuck until it sits just below the drill head.
2. Re-tighten the screw.

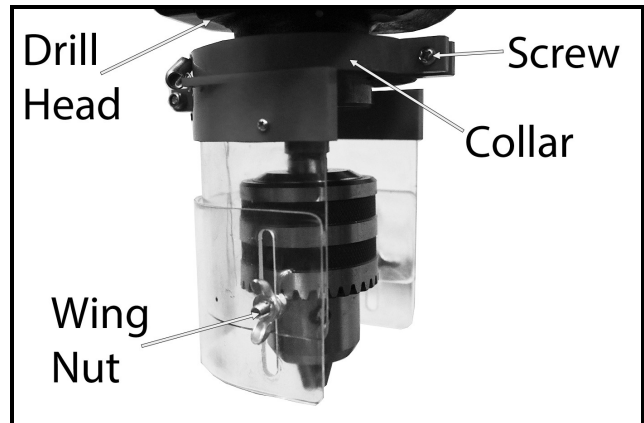

3. The guard height can be changed by loosening the wing nuts on either side and sliding the outer guard up or down.

NOTE: NEVER let the guard snap down on its own accord. **ALWAYS** raise and lower it by hand.

SETTINGS AND ADJUSTMENTS

TABLE

The table may be raised, lowered or swivelled around the column, by slackening off the table support locking handle on the back of the table support arm, adjusting accordingly and re-tightening the handle.

It may also be tilted by loosening the bolt beneath the table using a 19mm socket wrench or spanner, tilting the table to the required position and re-tightening the bolt as shown.

A bevel scale is provided on the table mounting, (measured in degrees, 45° left and right of horizontal, 0°), to assist in setting the required angle. However, for greater accuracy, the use of a protractor is recommended.

For all normal operations, the table should be set to 0°. To check to ensure the drill is entirely perpendicular to the

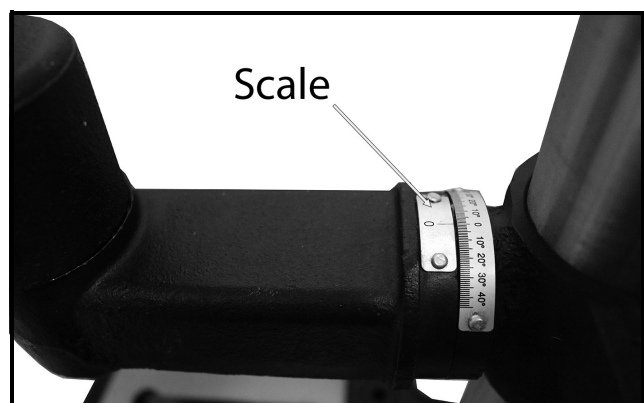
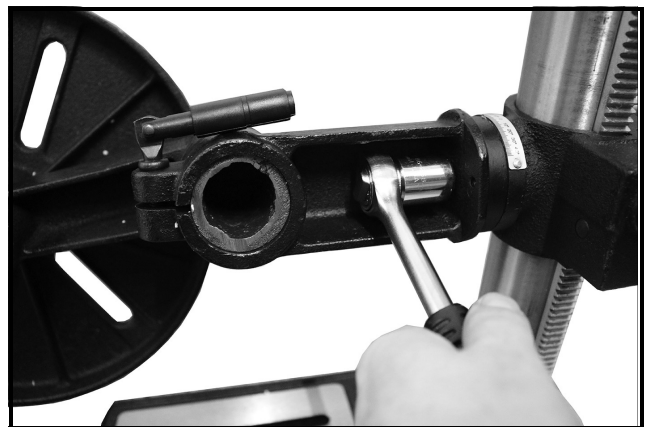

table, install a large drill bit in the chuck, place a set-square on the table, and bring it up to the drill. Adjust the table if necessary, so that it is perfectly level.

RADIAL ARM

To change the travel depth of the head along the radial, adjust the arm as follows:

1. Loosen the locking handle on the arm collar.
2. Turn the radial arm knob to move the drill head towards or away from the column.
3. Once the head is at the correct position, re-tighten the locking handle.



The drill head can rotate 90° left and 45° right to the horizontal. To achieve this adjust the arm as follows:

1. Loosen the locking handle on the arm collar.
2. On the other side of the collar, pull out and turn the guide pin 90° to lock it in the open position.

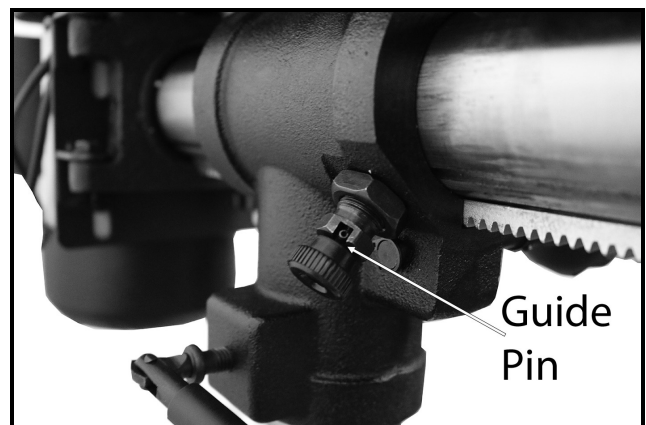

3. Rotate the radial arm to the required angle, using the scale on the collar and groove on the arm.
4. Once the head is at the correct angle, re-tighten the locking handle.

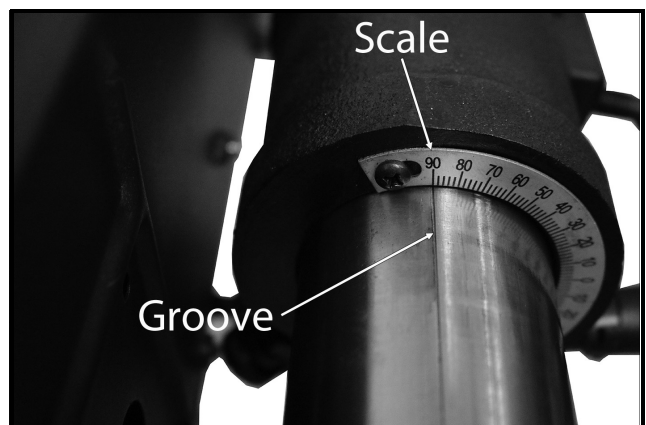

To return the radial arm to horizontal,

1. Loosen the locking handle.
2. Release the guide pin and rotate the radial arm.
3. The guide pin will automatically fall back into the guide groove on the radial arm.
4. Re-tighten the locking handle.

SPINDLE DEPTH SCALE

To set the depth of the hole, adjust the depth stop as follows:

1. Loosen the thumb screw on the inside of the feed handle.
2. Rotate the scale to the desired depth against the red zero marker (shown in inches and millimetres).
3. Re-tighten the thumb screw.



CHANGING DRILL SPEED

WARNING: BEFORE ATTEMPTING TO CHANGE THE DRILL SPEED MAKE SURE THE POWER IS SWITCHED OFF.

1. Open the belt cover by loosening the screw on the top cover.
2. Loosen the motor bracket that is situated at the end of the radial arm.
3. Consult the tables on pages 14 and 18, and set the belt on the pulleys according to the spindle speed required.

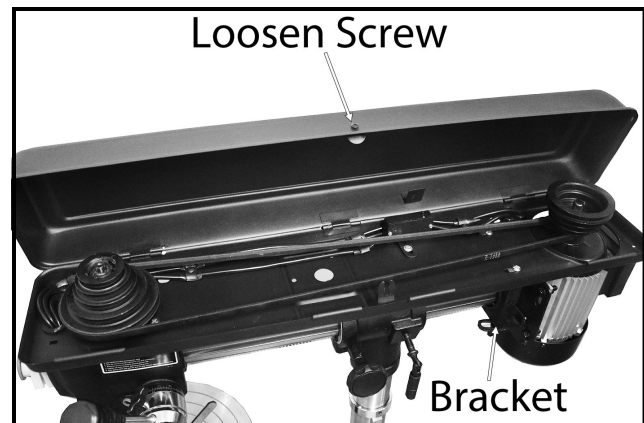

4. When the belt has been correctly positioned, re-tension by levering the motor away from the head until the belt deflects by approx. 1/2" at its centre when using reasonable thumb pressure.
5. Lock the motor in this position by re-tightening the motor bracket.

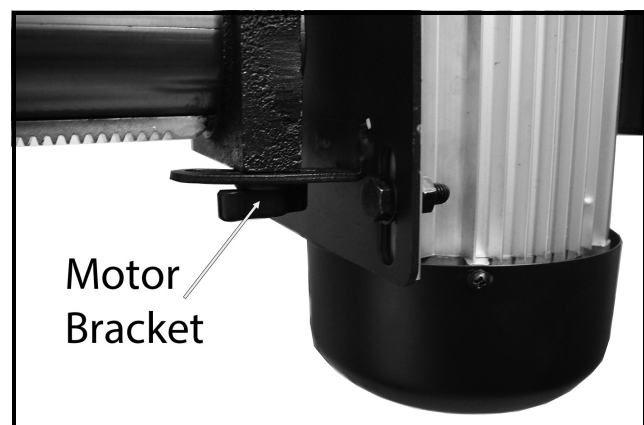

DRILL SPEED CHART

The table below gives the belt arrangement for given drill speeds.

A similar chart is also located on the inside of the pulley cover.



SPINDLE SPEED	BELT POSITION
348 rpm	1-A
610 rpm	2-B
990 rpm	3-C
1290 rpm	4-D
1710 rpm	5-E

OPERATION

1. Insert the drill bit into the jaws of the chuck by approx 1", ensuring that the jaws do not touch the flutes of the drill bit. Before tightening the chuck, ensure that the drill bit is centred within the jaws.
2. Ensure the table height and position is set, so that drill travel is sufficient for the job in hand.
3. Turn on the worklight to help position the workpiece.
 - Press the 'I' button to switch on.
 - Push the 'O' button to switch off.
4. Ensure the work is securely clamped or held in a drill vice, bolted to the table. Never hold it with bare hands. Personal injury may be caused if the workpiece is whipped out of the operators hand, and cause damage to anything it strikes.
5. If the workpiece is of irregular shape and cannot be laid flat on the table, it should be securely blocked and clamped.
6. Any tilting, twisting, or shifting results not only in a rough hole, but also increases drill bit breakage.
7. For small workpieces that cannot be clamped to the table, use a drill press vice. The vice must be clamped or bolted to the table.
8. When drilling completely through wood, always position a piece of scrap wood between the workpiece and the table to prevent splintering on the underside of the workpiece as the drill breaks through. The scrap piece of wood must make contact with the left side of the column to prevent it moving.
9. In addition, set the depth of drill travel so that the drill cannot possibly come into contact with the table, or align the table so that the hole in its centre is in line with the drill bit.
10. Form the habit of checking to see that the chuck key is removed from the machine before switching it on.

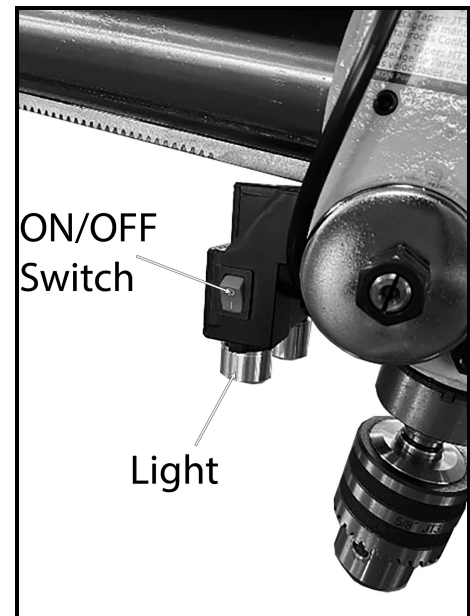

11. When completely satisfied that the setup is correct, move the chuck guard into position and switch the machine on.

- Press the 'I' button to switch on.
- Push the 'O' button to switch off.

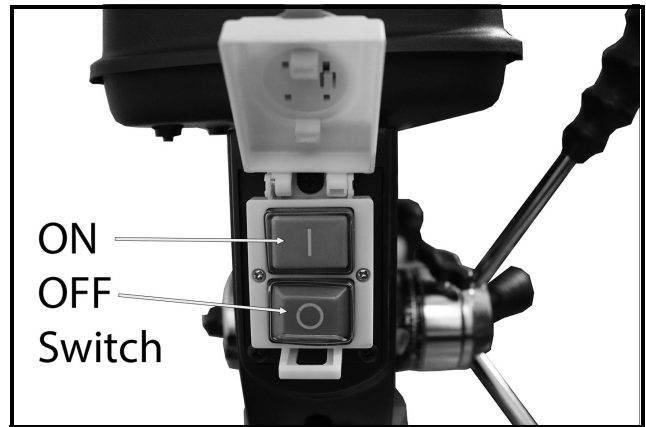

12. Lower the emergency stop cover, but DO NOT push it all the way home, as this will activate the emergency stop.

NOTE: In an emergency, hit the emergency stop button. To release the emergency stop, push the red button upwards.

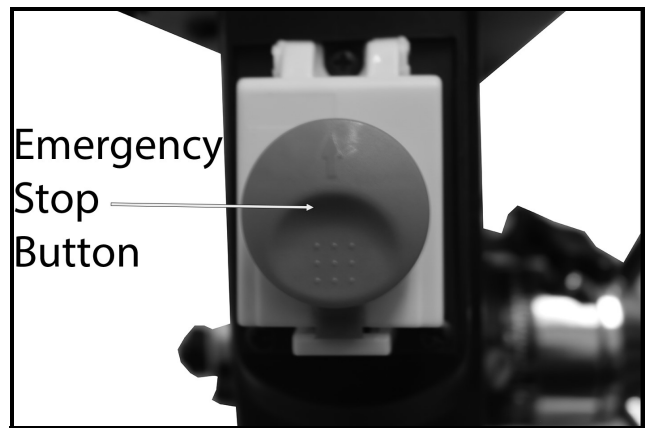

13. Slowly turn the feed handles to bring the drill bit down towards the table and into your workpiece. When drilling, ease the drill bit back up to clear swarf away as required. After drilling, release the feed handles slowly to return the machine to its starting position.

DRILL PRESS VICES

In order to secure the workpiece to the table, a selection of CLARKE drill press vices, cross vices and clamps are available, see page 20.

MAINTENANCE

For maximum performance, it is essential that the machine is properly maintained. **ALWAYS** inspect it before use. Any damage should be repaired, and faults rectified. **ALWAYS** unplug from the power supply before carrying out any adjustment, servicing or maintenance.

Please refer to the troubleshooting chart on page 19. If you are unable to rectify any faults, please contact your local dealer or Clarke Service Department for assistance.

MONTHLY (IF IN CONSTANT USE)

1. Check tightness of mounting bolts, and the head and column securing set screws.
2. Check the drive belt for wear, and replace if frayed or damaged.
3. Blow out with compressed air, or vacuum clean out, any dust that may have accumulated in the motor fan vents. NOTE: When using compressed air, always use eye protection.
4. Apply a thin coat of wax paste or light oil to the table and column, for lubrication, and to help prevent corrosion.

If the mains lead is damaged in any way it should be replaced immediately.

LUBRICATION

All bearings are packed with grease at the factory and require no further lubrication.

Occasionally, lubricate the quill shaft assembly with light oil if required.

AFTER USE

1. Remove all swarf from the machine and thoroughly clean all surfaces.
2. Components should be kept dry, with machined surfaces lightly oiled.
3. **ALWAYS** remove drill bits and store in a safe place.



RECOMMENDED DRILL SPEED/BIT SIZE

Factors which determine the best speed to use in any drill press operation are:

- Type of material being worked
- Size of hole
- Quality of cut desired
- Type of drill

As a guide, the drill speed for a given drill bit size, is according to the table below:

DRILL DIA.	SPEED RANGE (RPM)						
	WOOD	PLASTIC	ALUMIN.	BRASS/ BRONZE	STEEL - MILD	CAST IRON	STAIN LESS STEEL
1.5 mm	1700+	1700+	1700+	1700+	1700+	1700+	1680- 3640
3 mm	1700+	1700+	1700+	1700+	1700+	1700+	840- 1820
6 mm	1700+	1400- 2800	1700+	1700+	1120- 1330	1050- 1400	420- 910
10 mm	1700+	933- 1867	1700+	1700+	747- 887	700- 933	280- 607
13 mm	1700+	700- 1400	1400- 1750	1050- 1750	560- 665	525- 700	210- 455
16 mm	1680- 2128	560- 1120	1120- 1400	840- 1400	448- 532	420- 560	168- 364
19 mm	1400- 1773	467- 933	933- 1167	700- 1167	373- 443	350- 467	-
21 mm	1200- 1520	400- 800	800- 1000	600- 1000	320- 380	300- 400	-
25 mm	1050- 1330	350- 700	700- 875	525- 875	-	-	-
28 mm	933-1182	311-622	622-778	467-778	-	-	-
32 mm	840-1064	280-560	560-700	420-700	-	-	-
35 mm	764-967	255-509	509-636	382-636	-	-	-
38 mm	700-887	233-467	467-583	350-583	-	-	-

TROUBLE SHOOTING

PROBLEM	PROBABLE CAUSE	REMEDY
Noisy operation (under load).	<ul style="list-style-type: none"> a. Incorrect belt tension. b. Dry spindle. c. Loose spindle pulley. d. Loose motor pulley. 	<ul style="list-style-type: none"> a. Adjust tension. b. Lubricate spindle. c. Check tightness of retaining nut on pulley, and tighten if necessary. d. Tighten set screws in pulley.
Drill bit burns.	<ul style="list-style-type: none"> a. Incorrect speed. b. Chips not coming out of hole. c. Dull drill bit. d. Feeding too slow. e. Not lubricated 	<ul style="list-style-type: none"> a. Change speed (see page 13). b. Retract drill bit frequently to clear chips. c. Resharpen drill bit. d. Increase speed. e. Lubricate drill bit.
Drill bit leads off, hole not round.	<ul style="list-style-type: none"> a. Hard grain in wood or lengths of cutting lips and/or angles not equal. b. Bent drill bit. 	<ul style="list-style-type: none"> a. Resharpen drill bit correctly. b. Replace drill bit.
Wood splinters on underside.	<ul style="list-style-type: none"> a. No 'back up material' under workpiece. 	<ul style="list-style-type: none"> a. Use a 'back up material piece under the main workpiece..
Workpiece comes loose from hand.	<ul style="list-style-type: none"> a. Workpiece not supported or clamped correctly. 	<ul style="list-style-type: none"> a. Place workpiece in a vice or clamp to the table.
Drill bit binds in workpiece.	<ul style="list-style-type: none"> a. Workpiece pinching drill bit or excessive feed pressure. b. Improper belt tension. 	<ul style="list-style-type: none"> a. Support workpiece in a vice or clamp to table. b. Adjust tension in the pulley belt.
Excessive drill bit run-out or wobble	<ul style="list-style-type: none"> a. Bent drill bit. b. Worn spindle bearings. c. Drill bit not properly installed in chuck. d. Chuck not properly installed. 	<ul style="list-style-type: none"> a. Use a straight drill bit. b. Replace bearings. c. Install drill bit correctly. d. Install chuck correctly.
Quill returns too slow or too fast	<ul style="list-style-type: none"> a. Spring has improper tension. 	<ul style="list-style-type: none"> a. Adjust spring tension.
Chuck will not stay attached to spindle or falls off when trying to install it.	<ul style="list-style-type: none"> a. Dirty, grease or oil on the tapered inside surface of chuck or on the spindle tapered surface. 	<ul style="list-style-type: none"> a. Using a household detergent, clean the tapered surface of the chuck and spindle to remove all dirt, grease and oil.

NOTE: If you are unsure of any of these remedies, please contact the CLARKE service department.

SUITABLE ACCESSORIES

Drill Press Vices available from your CLARKE dealer include:

Model	Jaw Width	Max Opening	Depth	Weight	Part No
CDV30C	76 mm	78 mm	19 mm	2 kg	6504019
CDV40C	102 mm	97 mm	28 mm	3 kg	6504020
CDV50C	127 mm	125 mm	37 mm	5 kg	6504021
CDV60C	152 mm	150 mm	38 mm	6 kg	6504022

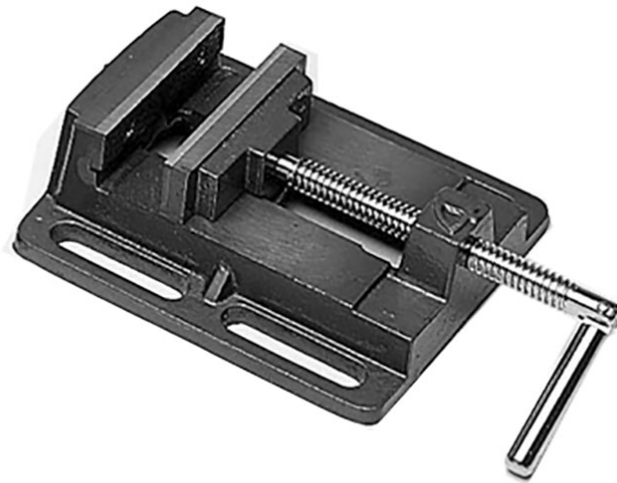

Table Clamps available from your CLARKE dealer include:

Model	Size	Max Clamp Height	Part No
CVC6	152 mm	38 mm	6501920
CVC9	229 mm	95 mm	6501925

SPECIFICATION

Model	CDP425RA
Operating Temperature Range	0°C - 40°C
Drill Chuck Capacity	1 - 16 mm
Overall Dimensions (D x W x H)	930 x 300 x 845 mm
Table Dimension	300mm diameter
Base Dimensions	413 x 246 mm
Spindle Centre to Column Distance	150 - 340 mm
Spindle to Table Max. Distance	350 mm
Spindle to Base Max. Distance	470 mm
Spindle Rotary Angle	90° Left - 0 - 45° Right
Table Angle	45°
Table Travel (Up/Down)	265 mm
Radial Arm Travel	190 mm
Spindle Speed Range	348 - 1710 rpm
No of Speeds	5
Spindle Taper	MT2
Spindle Travel (Quill Stroke)	80 mm
Product Weight	44.85 kg
Power Supply	230Vac/50Hz/1ph
Power Rating	425 W
Input Current	1.9 A
Electrical Protection Classification	Class 1
Motor Duty Cycle	S1 Continuous
IP Rating	IP44
Sound Power Level	<85 dB LWA

ENVIRONMENTAL PROTECTION



Recycle unwanted materials instead of disposing of them as waste. Any tools, accessories and packaging should be sorted, taken to a recycling centre and disposed of in a manner which is compatible with the environment.



Recycling packaging reduces the need for landfill and raw materials. Re-use of recycled materials decreases pollution in the environment. Please re-cycle packaging where facilities exist. Check with your local council authority for recycling advice.

PARTS DIAGRAM

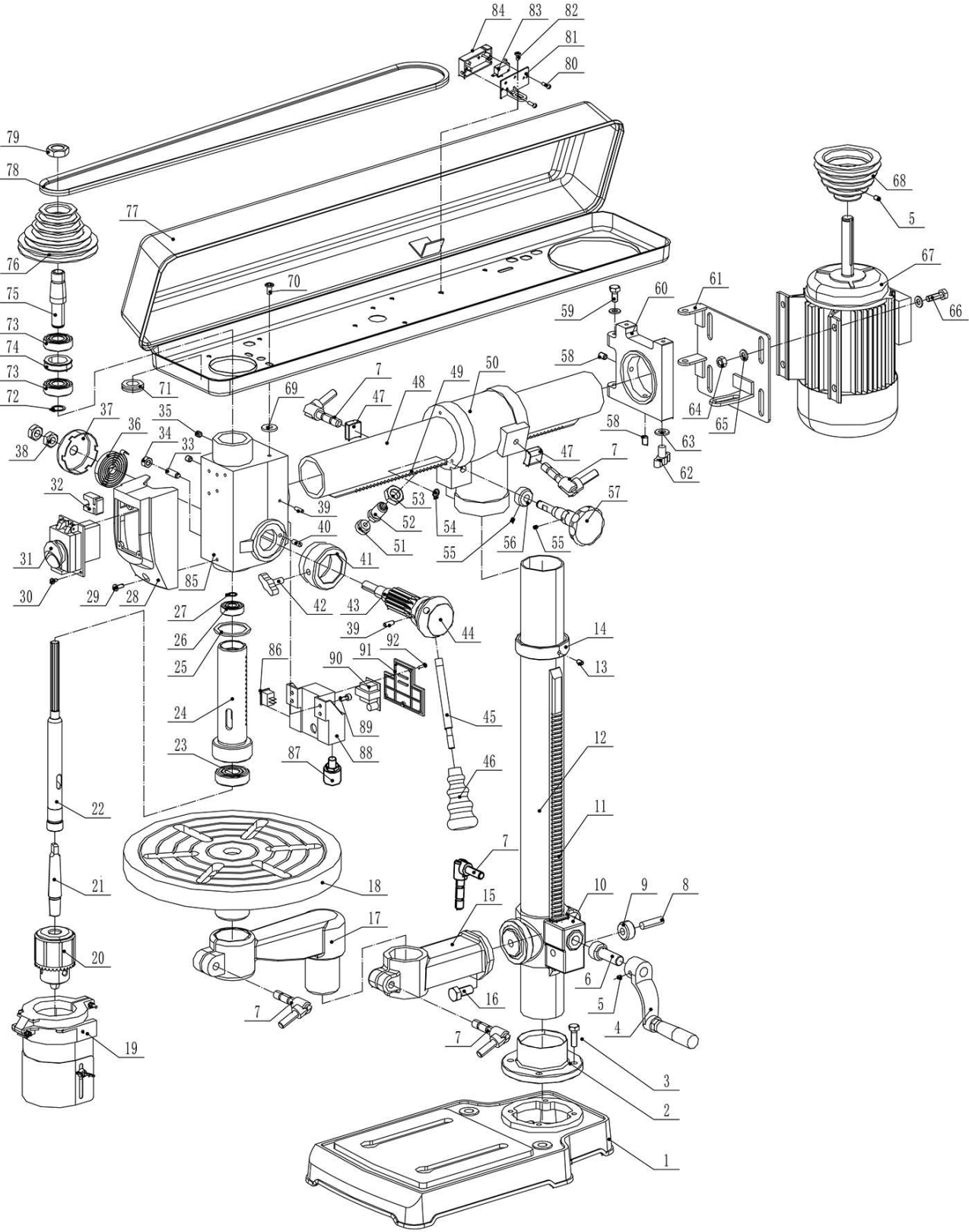

PARTS LIST

No	Description
1	Base
2	Column Seat
3	Hex Bolt M8 x 20
4	Crank
5	Screw M6 x 10
6	Worm Gear Elevation
7	Support Clamp
8	Pin Gear
9	Helical Gear
10	Table Support
11	Rack
12	Column
13	Screw M10 x 12
14	Column Collar
15	Arm
16	Hex Bolt M16 x 35
17	Extend Arm
18	Table
19	Chuck Guard
20	Chuck
21	Arbor
22	Spindle
23	Bearing - Ball 60204
24	Tube - Quill
25	Rubber Washer
26	Bearing - Ball 60203
27	Retaining Ring
28	Box Switch
29	Screw-pan HD M5 x 12
30	Self Tapping Screw 4.2

No	Description
31	Magnetic Switch
32	Key Storage
33	Pin Roll
34	Screw Nut
35	Screw Socket Set
36	Torsion Spring
37	Cap Spring
38	Hex Nut
39	Pin Stop
40	Pin Roll
41	Ring Depth Stop
42	Lock Depth Screw
43	Gear Shaft
44	Handle Seat
45	Feed Rod
46	Feed Knob
47	Locking Shoe
48	Horizontal Tube
49	Horizontal Rack
50	Guide Column
51	Composite Nut
52	Position Adjustment Assembly
53	Screw Nut M8
54	Shaft Retaining Ring
55	Hexagon Socket Screw M5 x 6
56	Bevel Gear
57	Moving Bar
58	Screw
59	Bolt
60	Mount Cover

PARTS LIST

No	Description
61	Mount Motor
62	Thumb Nut
63	Washer
64	Hex Nut M8
65	Washer M8
66	Bolt
67	Motor
68	Motor Pulley
69	Screw M6 x 10
70	Screw
71	Clamp
72	Locking Ring
73	Bearing - Ball
74	Spacer
75	Insert Pulley
76	Spindle Pulley

No	Description
77	Belt Guard
78	V Belt
79	Pulley Nut
80	Self Tapping Screw
81	Micro-switch Cover
82	Pan Head Screw M4 x 8
83	Micro-Switch
84	Micro-Switch Cover
85	Case
86	Light Switch
87	LED Light
88	Light Box
89	Screw
90	Transformer
91	Light Box Cover
92	Self Tapping Screw

DECLARATION OF CONFORMITY - UKCA



Hemnall Street, Epping, Essex, CM16 4LG

DECLARATION OF CONFORMITY

This is an important document and should be retained.

We hereby declare that this product(s) complies with the following legislation:

The Electromagnetic Compatibility Regulations 2016

The Supply of Machinery (Safety) Regulations 2008

The Restriction of the Use of Certain Hazardous Substances in Electrical and Electronic Equipment Regulations 2012

The following standards have been applied to the product(s):

EN 61000-6-3:2007+A1:2011+AC:2012, IEC 62321-5 Edition 1.0:2013, EN 61000-3-3:2013+A1:2019, IEC 62321-4 Edition 1.0:2013+A1, IEC 62321-7-1 Edition 1.0:2015, IEC 62321-7-2 Edition 1.0:2017, IEC 62321-3-1 Edition 1.0:2013, IEC 62321-6 Edition 1.0:2015, EN IEC 61000-3-2:2019, EN IEC 61000-6-1:2019, IEC 62321-8:2017

The technical documentation required to demonstrate that the product(s) meet(s) the requirement(s) of the aforementioned legislation has been compiled and is available for inspection by the relevant enforcement authorities.

The UKCA mark was first applied in: 2024

Product Description: Drill Press
Model Number(s): CDP425RA
Serial/Batch Number: Refer to product/package label
Date of Issue: 14/06/2024

Signed:

J.A Clarke

Director

DECLARATION OF CONFORMITY - CE



Clarke[®]
INTERNATIONAL

Fitzwilliam Hall, Fitzwilliam Place, Dublin 2

DECLARATION OF CONFORMITY

This is an important document and should be retained.

We hereby declare that this product(s) complies with the following legislation:

2014/30/EU *Electromagnetic Compatibility Directive*
2006/42/EC *Machinery Directive*
2011/65/EU *Restriction of Hazardous Substances (RoHS) Directive*

The following standards have been applied to the product(s):

*EN 61000-6-3:2007+A1:2011+AC:2012, IEC 62321-5 Edition 1.0:2013, EN 61000-3-3:2013+A1:2019,
IEC 62321-4 Edition 1.0:2013+A1, IEC 62321-7-1 Edition 1.0:2015, IEC 62321-7-2 Edition 1.0:2017,
IEC 62321-3-1 Edition 1.0:2013, IEC 62321-6 Edition 1.0:2015, EN IEC 61000-3-2:2019,
EN IEC 61000-6-1:2019, IEC 62321-8:2017*

The technical documentation required to demonstrate that the product(s) meet(s) the requirement(s) of the aforementioned legislation has been compiled and is available for inspection by the relevant enforcement authorities.

The CE mark was first applied in: 2024

Product Description: Drill Press
Model Number(s): CDP425RA
Serial/Batch Number: Refer to product/packaging label
Date of Issue: 14/06/2024

Signed:

J.A Clarke
Director

A SELECTION FROM THE VAST RANGE OF

Clarke®

QUALITY PRODUCTS



AIR COMPRESSORS
From DIY to industrial, Plus air tools, spray guns and accessories.

GENERATORS
Prime duty or emergency standby for business, home and leisure.

POWER WASHERS
Hot and cold, electric and engine driven - we have what you need

WELDERS
Mig, Arc, Tig and Spot. From DIY to auto/industrial.

METALWORKING
Drills, grinders and saws for DIY and professional use.

WOODWORKING
Saws, sanders, lathes, mortisers and dust extraction.

HYDRAULICS
Cranes, body repair kits, transmission jacks for all types of workshop use.

WATER PUMPS
Submersible, electric and engine driven for DIY, agriculture and industry.

POWERTOOLS
Angle grinders, cordless drill sets, saws and sanders.

STARTERS/CHARGERS
All sizes for car and commercial use.



PARTS & SERVICE: 0208 988 7400

Parts Enquiries
Parts@clarkeinternational.com

Servicing & Technical Enquiries
Service@clarkeinternational.com

SALES: UK 01992 565333 or Export 00 44 (0)1992 565335

Clarke INTERNATIONAL Hemnall Street, Epping, Essex CM16 4LG
www.clarkeinternational.com